

**New
and
Improved!**



DESCRIPTION

Experts all agree that clean, dry parts and equipment are fundamental to high first-run capability. The AC5000 Robotic Applicator Cleaner provides superior quality cleaning for both bell and gun applicators.

Dirty applicators cause drips, spits, KV faults and poor paint application. The AC5000 effectively cleans and dries dirty applicators, eliminating paint defects caused by applicator contamination saving millions of pounds in wasted time, paint, parts and man-hours.

Operation is simple. The dirty applicator is inserted into the cleaner. Inside, air creates a vacuum and the applicator is washed from top to bottom with solvent as the applicator moves up out of the cleaner. At the top of the cleaner the applicator is air-dried before the cleaner automatically shuts off.

The AC5000 Robotic Applicator Cleaner is the only solution for effectively cleaning robotic paint applicators.

FEATURES AND BENEFITS

- **Patented Air Seal**...means no physical contact with the applicator
- **Eliminates all paint defects caused by dirty applicators**...Improving quality & FTC
- **>90% Capture Efficiency**...saves material and solvent, reducing VOC emissions.
- **Lowest solvent and air consumption.**
- **Flexible**...can be used on bell or gun type applicators, solvent or waterborne.
- **Minimum maintenance**...no moving parts to clean.
- **Easy Installation**...installs within hours, allowing for minimal disruption.
- **Instant results**...once installed, the paint line group will benefit from instant, direct and measurable improvements.



The Applicator Cleaner cleaning a bell-type atomizer.

SPECIFICATIONS

Airline supply: 10mm air
Footprint: 35cm x 35cm
Air Pressure: 3 bar*
Air Consumption: 17.4 cfm
Funnel Nipple: 2" npt
Solvent/Air used for average cleaning cycle: 60 cc solvent/1.74 ft³ air

*pressure setting is very important and must be set properly for the cleaner to function correctly and perform self-cleaning.

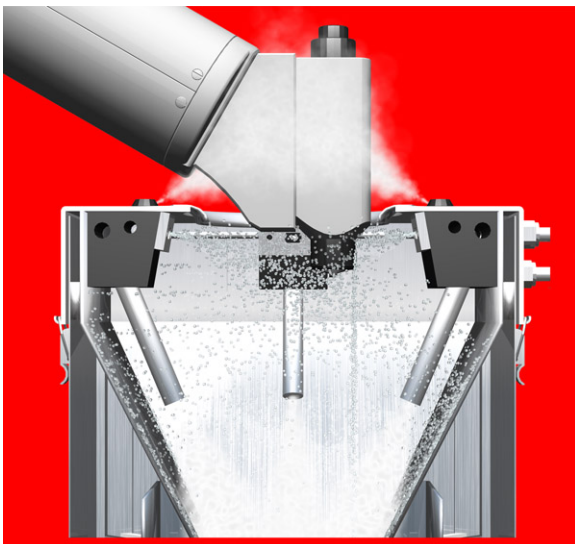
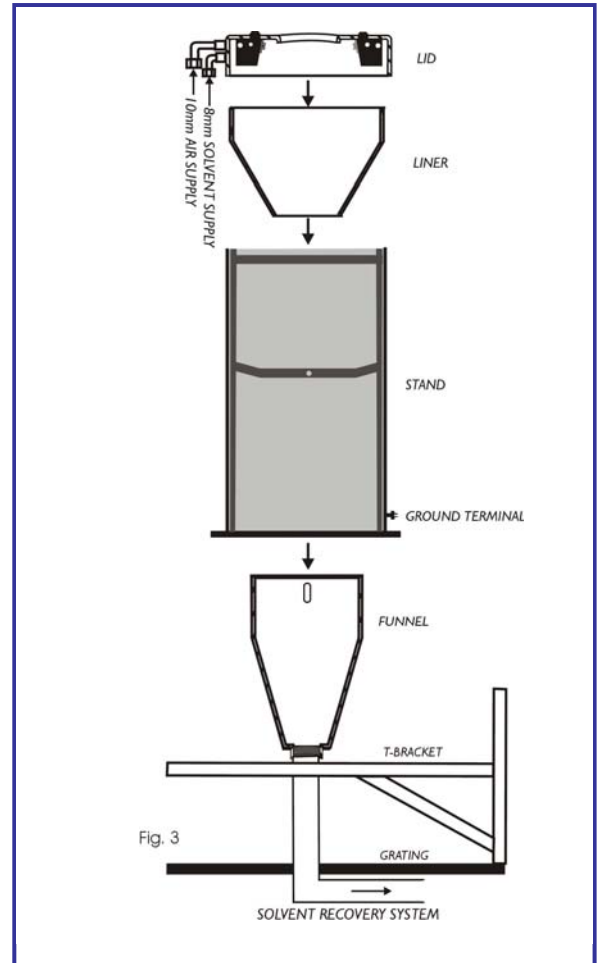

The Applicator Cleaner cleaning a gun-type atomizer.